



Syfer Technology Limited, Old Stoke Road,
Arminghall, Norwich, Norfolk, NR14 8SQ,
United Kingdom
Tel: +44 (0) 1603 723300
Tel. (Sales): 01603 723310
Fax: +44 (0) 1603 723301
Email: sales@syfer.co.uk
Web: www.syfer.com

Tin Whiskers

Syfer Surface Mount Capacitors

Contents

1. [Introduction](#)
2. [Syfer Surface Mount Terminations](#)
 - 2.1 [Syfer Terminations Available](#)
 - 2.2 [Part Number Construction](#)
3. [Tin Whisker Mitigation Practices](#)
4. [Syfer 100% Tin Termination Whisker Tests](#)
 - 4.1 [Tin Whisker Tests](#)
 - 4.2 [Termination Tin Whisker Inspection](#)
 - 4.3 [Whisker Test Summary](#)

[Appendix 1 – SEM Images](#)



1. Introduction

With the implementation of legislation such as the EU RoHS directive prohibiting Lead (Pb) from many applications there has been a growing concern within the electronics industry that there is an increased risk of Tin whisker formations causing equipment failure.

Tin whiskers are filaments of Tin that form/ emanate from a pure Tin or plated Tin surface with the potential reliability risk that a Tin whisker may create a short circuit or an intermittent equipment failure. Information available on NASA website <http://nepp.nasa.gov/whisker/failures/index.htm> includes some of the equipment failures attributed to Tin whiskers and also provides photographs of Tin whiskers.

Extensive work has been conducted, for example by NASA and iNEMI (International Electronics Manufacturing Initiative) into understanding causes for Tin whisker formation. It is believed that stresses within the Tin such as from intermetallic formations, oxidisation/ corrosion, thermal stress (temperature cycling) and/ or mechanical stress may contribute to Tin whisker formation.

iNEMI has been involved in Tin whisker research since 2001 and provides recommendations on Lead-free finishes. For example, 100% Tin plated surface mount capacitors manufactured by Syfer (matte Tin with Nickel underplate, ceramic capacitors with no leadframe) have been classified by iNEMI as category 1 (no Tin whisker testing required) or 2 (finish must pass Tin whisker testing). iNEMI category 3 (do not accept this finish in any case) including Tin copper and bright Tin are not manufactured by Syfer.

View iNEMI recommendations at <http://www.inemi.org/cms/newsroom/PR/2006/PR121506.html>.

In addition to this, there are several stress tests recommended by, for example, JEDEC (refer to JEDEC JESD22A121 available at www.jedec.org) and AEC (refer to AEC-Q200 available at www.aecouncil.com). Note: The tests are recommended tests and are not provided as qualification tests.

2. Syfer Surface Mount Terminations

When reviewing Tin whisker information it is often stated that component manufacturers have changed component plated finishes from Tin/ Lead to 100% Tin in response to legislation such as the EU RoHS directive. This statement is not true for Syfer capacitors; there has been no change from Tin/ Lead to 100% Tin plating on surface mount components. Syfer has supplied 100% Tin plated components to customers for many years.

However, in response to customer demand, Syfer has increased the Lead content in Tin/ Lead plated components to a minimum of 10% Lead.

2.1 Syfer Terminations Available

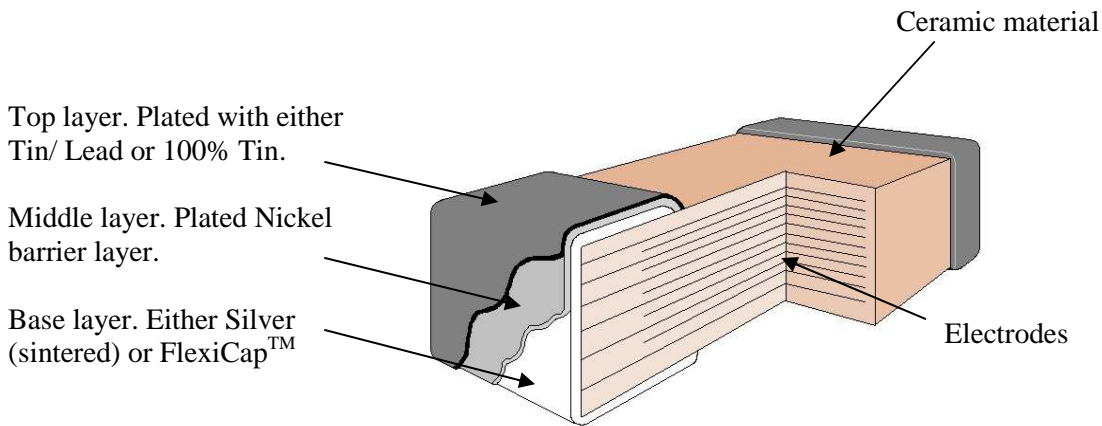

Fig. 1. Capacitor construction diagram

Table 1 – Syfer Terminations

Termination Description	Syfer Part Code	Base Layer	Middle Plated Layer	Top Plated Layer	RoHS Compliant?	iNEMI Tin Whisker Test Category
Silver Palladium	F	Silver Palladium	Not applicable	Not applicable	Yes	Not required, no Tin finish
Nickel Barrier with Tin/ Lead Plating	A	Silver base	Nickel	Tin/Lead with minimum 10% Lead	No	Not required, Lead present in top layer
Nickel Barrier with 100% Matte Tin Plating	J	Silver base	Nickel	100% Matte Tin	Yes	1 or 2 ⁽¹⁾
FlexiCap™, Nickel Barrier with Tin/ Lead Plating	H	Silver base	Nickel	Tin/Lead with minimum 10% Lead	No	Not required, Lead present in top layer
FlexiCap™, Nickel Barrier with 100% Matte Tin Plating	Y	Silver base	Nickel	100% Matte Tin	Yes	1 or 2 ⁽¹⁾

Notes:

(1) Category 1: No Tin whisker testing required.

Category 2: Finish must pass Tin whisker testing.

iNEMI explains that both categories have been assigned because in general Tin whisker tests are required but many users have accepted small discrete capacitors with matte Tin over Nickel for many years. Small discrete capacitors are exceptions to the Tin whisker test requirement providing certain criteria are met.



2.2 Part Number Construction

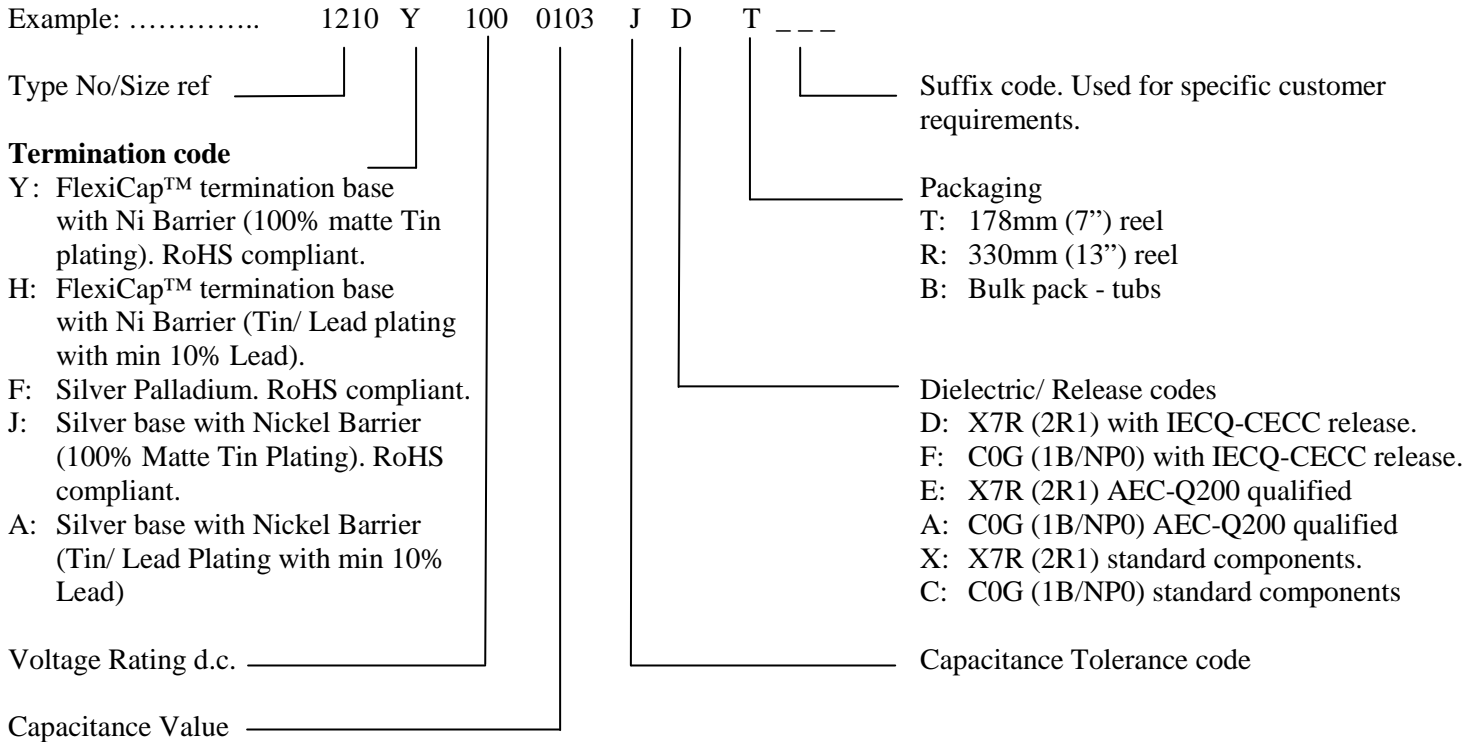

For questions or quotation please contact Syfer Sales department.

3. Tin Whisker Mitigation Practices

The following Tin whisker mitigation practices are employed by Syfer:

- Matte Tin plating with Nickel underplate.
- Tin plating thickness >2µm.
- Annealing process after plating for 150°C for minimum of 2 hours.
- No Lead forming or other stress creating operations after plating.

4. Syfer 100% Tin Termination Whisker Tests

In response to general customer enquires regarding Tin whiskers on Syfer 100% Tin plated capacitors, components have been subjected to the following tests with the purpose of accelerating Tin whisker growth.

Tin whisker maximum specification (AEC-Q200 section 4.3.4.2): 50µm.

4.1 Tin Whisker Tests

Table 2 - Tin Whisker Growth Tests

Stress Type	Test Conditions	Minimum Duration
Temperature Cycling	Tmin: -55°C Tmax: +125 °C	1000 cycles
Ambient Temperature/ Humidity Storage	30°C 60%RH	3000 hours with 1000 hour inspection intervals
High Temperature/ Humidity Storage	60°C 87%RH	3000 hours with 1000 hour inspection intervals

4.2 Termination Tin Whisker Inspection

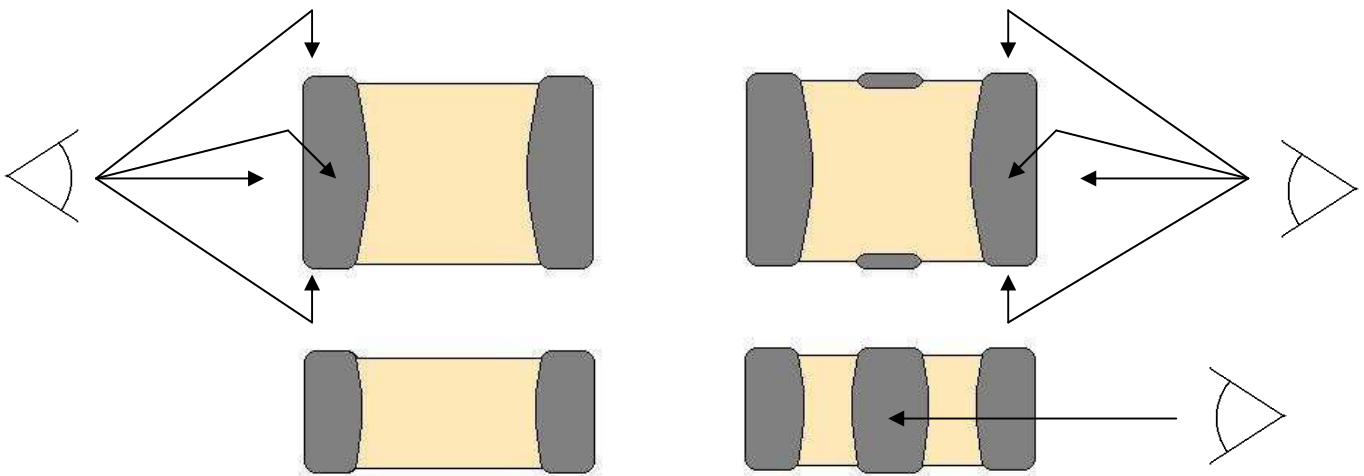

Fig. 2. Diagrams showing 2 terminal and 3 terminal components

Inspection conducted using optical microscope with 50x to 500x magnification and SEM (Scanning Electron Microscope) with minimum of 250x magnification. All termination tops and sides examined for Tin whiskers.



4.3 Whisker Test Summary

Table 3 – Syfer Capacitor Test Results: **Nickel Barrier with 100% Matte Tin Plating**

Capacitor Case Size	Sample Size		Tin Whisker Test Result			Appendix 1 SEM Photo Ref
	Number of components	Number of Terminations	Temp Cycle	30°C 60%RH	60°C 87%RH	
0603 (2 terminals)	18	36	Pass No whiskers	Pass No whiskers	Pass No whiskers	1
0805 (2 terminals)	9	18	Pass No whiskers	Pass No whiskers	Pass No whiskers	2
0805 (3 terminals)	18	72	Pass No whiskers	Pass No whiskers	Pass No whiskers	3, 4
1206 (3 terminals)	9	36	Pass No whiskers	Pass No whiskers	Pass No whiskers	5, 6
1410 (3 terminals)	18	72	Pass No whiskers	Pass No whiskers	Pass No whiskers	7, 8
1806 (3 terminals)	18	72	Pass No whiskers	Pass No whiskers	Pass No whiskers	9
1812 (2 terminals)	9	18	Pass No whiskers	Pass No whiskers	Pass No whiskers	10
1812 (3 terminals)	18	72	Pass No whiskers	Pass No whiskers	Pass No whiskers	11, 12

Appendix 1 – SEM Images

The following images have been taken using a SEM (Scanning Electron Microscope) after the Tin whisker tests and are representative of the terminations examined.

0603 (2 terminals)

Ref 1.

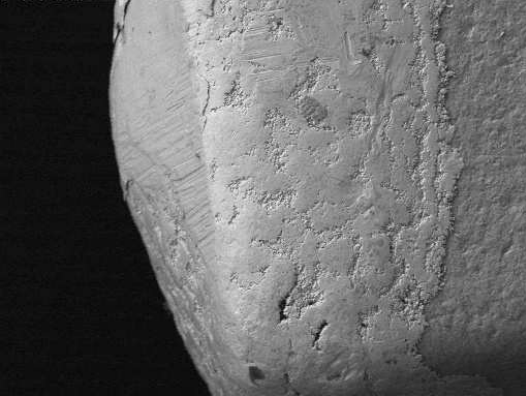

0805 (2 terminals)

Ref 2.



0805 (3 terminals)

Ref 3. End termination.



Ref 4. Side termination.



1206 (3 terminals)

Ref 5. End termination.



Ref 6. Side termination

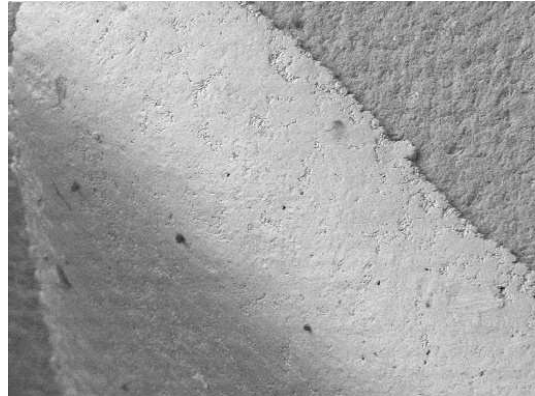

1410 (3 terminals)
Ref 7. End termination.

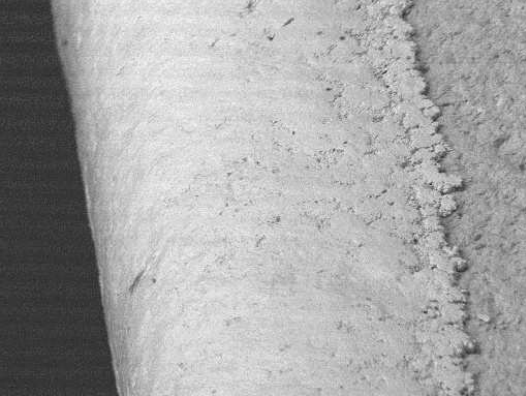

Ref 8. Side termination



1806 (3 terminals)
Ref 9. End termination.



1812 (2 terminals)
Ref 10.



1812 (3 terminals)
Ref 11. End termination.



Ref 12. Side termination

