



Syfer Technology Limited, Old Stoke Road,
Arminghall, Norwich, Norfolk, NR14 8SQ,
United Kingdom
Tel: +44 (0) 1603 723300.
Tel. (Sales): 01603 723310
Fax: +44 (0) 1603 723301
Email: sales@syfer.co.uk
Web: www.syfer.com

Bend Testing

Methods and International Specifications

Introduction	2
International Requirements/ Specifications	2
Capacitor Bend Tests Conducted on Syfer Product	3
Mechanical Crack Shape	6
Summary	7



Introduction

Due to its brittle nature, multilayer ceramic capacitors are more prone to excesses of mechanical stress than other components used in surface mounting. One of the most common causes of capacitor failures is directly attributable to the bending of the printed circuit board (PCB) after solder attachment. Excessive bending will create mechanical stress within the ceramic capacitor that, if sufficient, can result in mechanical cracks.

The purpose of this report is to provide details regarding:

- a. International Specifications that define bend test methods and acceptability.
- b. Methods employed by Syfer to measure the mechanical performance of the termination material.
- c. The shape of cracks created by PCB bending - mechanical stress.

International Requirements/ Specifications

The international requirement for bend testing is referred to in several different specifications.

1. IEC 60384-1:2001 Fixed capacitors for use in electronic equipment Part 1: Generic Specification section 4.35 Substrate bending test refers to IEC 60068-2-21.
2. IEC 60068-2-21: 1999 Environmental testing: Test U: Robustness of Terminations and Integral Mounting Devices. Section 8 test Ue specifies the test required to assess the mechanical robustness of surface mounting device terminations when mounted on a substrate. Test Ue₁ specifies the substrate bend test.

The purpose of test Ue₁ is to verify that the capacitors can withstand bending loads that are likely to be applied during normal assembly or handling operations.

IEC 60068-2-21 refers to requirements such as deflection and acceptance criteria as being included in the “relevant specification”. Syfer maintains IECQ CECC (International Electrotechnical Commission Quality certification programme- CENELEC Electronic Components Committee) product approval and the “relevant specification” is QC 32100-A001:2007.



3. QC 32100-A001:2007 Table 2 – Periodic Tests defines board flex minimum requirements as:
COG: All types, X7R: Y and H only (Flexicap™)
3mm deflection Class I.
2mm deflection Class II.

X7R (non – Flexicap™ termination) 1mm deflection.
4. AEC-Q200-005, Board Flex / Terminal Bond Strength Test.
Minimum requirements stated in table 2 stress test reference 21: 2mm (min) for all except 3mm for Class I.

Capacitor Bend Tests Conducted on Syfer Product

Currently there are 2 methods employed by Syfer to measure the mechanical performance of capacitor termination when mounted on a substrate:

1. External Test Laboratory

To maintain IECQ CECC product approval (certified by BSI “British Standards Institute”) Syfer issues capacitor samples to an external test laboratory for a variety of tests to be conducted in accordance with IECQ CECC requirements. The external test laboratory is not part of Syfer and has full traceability to International Reference Standards.

Syfer has maintained CECC product approval for >20 years.

2. Syfer Bend Tests

In addition to the external test laboratory Syfer also conducts bend tests. Samples of capacitors are mounted onto FR4 Test PCBs using 62/36/2 Sn/Pb/Ag solder and subjected to bend testing in accordance with IECQ CECC or AEC –Q200-005 (depending on termination and dielectric types).

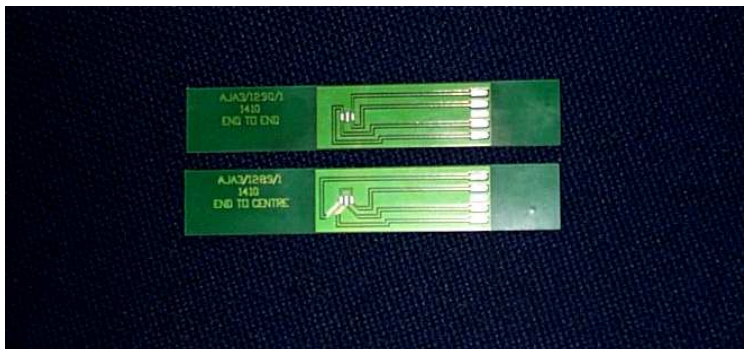

Example of FR4 Test PCB Used



Capacitor Placement Method

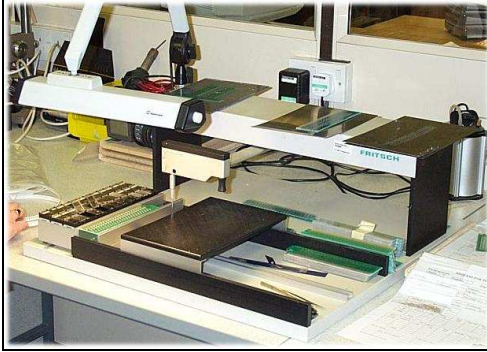

Hand pick and place used to mount capacitors for bend tests.

Syfer's Bend Test Facility



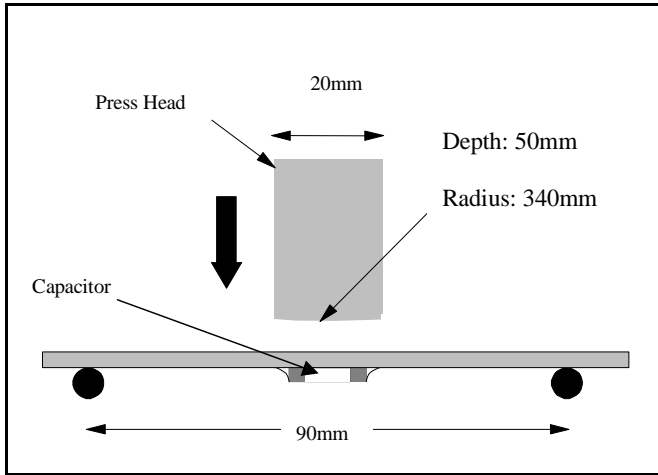

Fig 1. Bend Test Method



A total of 10 Test PCBs are used for each bend test. Each PCB is mounted with one capacitor and deflected automatically until the capacitor breaks. The software analyses the change in capacitance measured by the Agilent 4288A capacitance meter. As soon as the capacitance change is greater than 10% the bend is recorded in mm.

The results of the test are saved to the Syfer network but also can be communicated as a printed document as below.

Bend Test Data:

Batch Number: G89040
Part number: 0805Y2000221* C000
Data folder: 0805\G89040_1

Sample size: 10
Updated by: P Taylor
Date: 23-Oct-2007

Measured results

Sample No:	1% cap. change	10% cap. change	Sample No:	1% cap. change	10% cap. change	Sample No:	1% cap. change	10% cap. change
1	>9.963	>9.963	11			21		
2	>9.998	>9.998	12			22		
3	>10.003	>10.003	13			23		
4	>10.052	>10.052	14			24		
5	>9.901	>9.901	15			25		
6	>9.978	>9.978	16			26		
7	>9.966	>9.966	17			27		
8	>9.959	>9.959	18			28		
9	>9.993	>9.993	19			29		
10	>10.000	>10.000	20			30		

Extrapolated summary statistics for 10% cap. change:
Mean: >10.000
Standard deviation: Mean - 3 std. devn: Max: >10.000
Mean + 3 std. devn: Min:

Comment: ROUTINE BEND TEST

Document shows the results for Flexicap™ terminated components.

Typical results for Syfer X7R 0805, 1206, 1812 and 2220 capacitor ranges:

PRODUCT	MEAN BEND (mm) Sintered Termination	Mean Bend (mm) Flexicap™ Termination
0805 X7R	3.6	6.3
1206 X7R	3.4	6.4
1812 X7R	3.2	6.0
2220 X7R	3.2	6.1

Mechanical Crack Shape

By conducting extensive bend testing capacitor manufacturers including Syfer have demonstrated that mechanical stress applied by bending the PCB results in a distinctive type of crack within the capacitor.

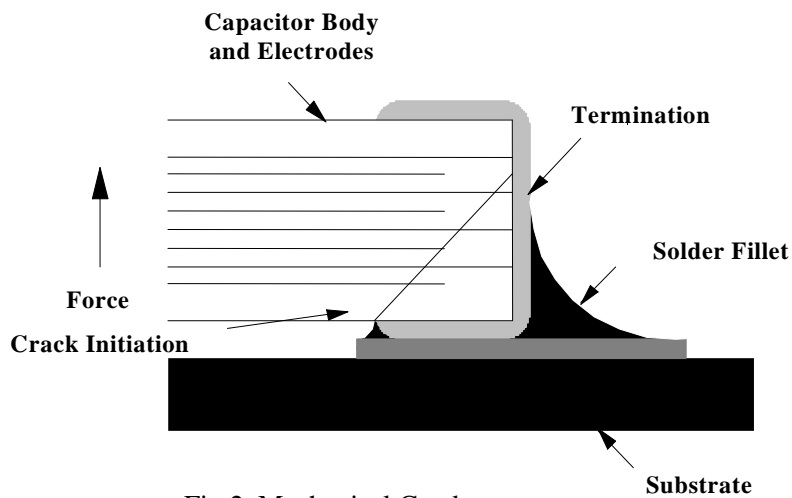
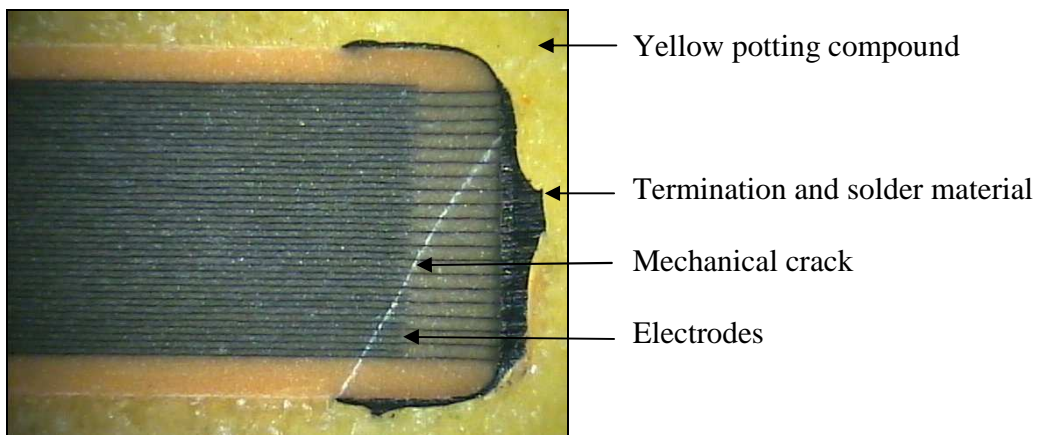

Fig 2. Mechanical Crack

During Syfer's investigation into mechanical cracking over 15000 capacitors were subjected to bend testing.

Example of capacitors issued by customers to Syfer for failure investigation:





Summary

- Syfer capacitors pass the International Specifications for bend testing. In addition to routine tests conducted at Syfer an external test laboratory conducts periodic IECQ CECC tests on Syfer product including bend testing.
- The crack created by mechanical stress during PCB bending is a distinctive type of crack.

For further information regarding:

- a) Potential causes for mechanical cracking refer to Syfer application note “Mechanical Cracking” application note reference AN0005.
- b) FlexicapTM. Refer to “FlexicapTM Termination” application note reference AN0001.
- c) AEC-Q200. Refer to “AEC-Q200 Stress Test Qualification for Passive Components” application note reference AN0009.

Information is also available on Syfer’s web site www.syfer.com