



Syfer Technology Limited, Old Stoke Road,
Arminghall, Norwich, Norfolk, NR14 8SQ,
United Kingdom
Tel: +44 (0) 1603 723300.
Tel. (Sales): 01603 723310
Fax: +44 (0) 1603 723301
Email: sales@syfer.co.uk
Web: www.syfer.com

X2Y Balanced Line EMI Chip

Reliability and Performance Data

[Introduction](#)

[Specifications](#)

[Component Diagrams](#)

[Technical Benefits](#)

[Applications](#)

[Reliability Information](#)

[Load Test](#)

[X2Y FIT Rates](#)

[Humidity Tests](#)

[Performance Information](#)

[Capacitance vs. Time](#)

[IR vs. Temperature](#)

[DF vs. Temperature](#)

[Rated Voltage vs. Temperature](#)

[Temperature Coefficient](#)

[Voltage Coefficient](#)



Introduction

The X2Y Balanced Line EMI Chip is a 3 terminal device with a revolutionary internal design, offering simultaneous line-to-line and line-to-ground filtering, using a single chip. The novel electrode structure provides a much reduced inductance when compared to conventional capacitors, which enhances the high frequency filtering performance.

Capable of replacing two or more conventional devices, typical applications include the suppression of EMI in DC motors for automotive products, eg window lifters, mirror motors, seat adjustment etc.

X2Y components are available in case sizes of 0805 up to 2220, capacitance values from 10pF to 1.2uF.

Specifications

Dielectric:	X7R or C0G/ NP0
Capacitance Measurement:	At 1000hr point
Typical Capacitance Matching:	Better than 5%
Temperature Rating:	-55°C to 125°C
Dielectric Withstand Voltage:	2.5 x Rated Volts for 5 secs. Charging current limited to 50mA max.
Insulation Resistance:	100GOhms or 1000S (whichever is the less).
Termination Material:	Nickel Barrier.

Component Diagrams

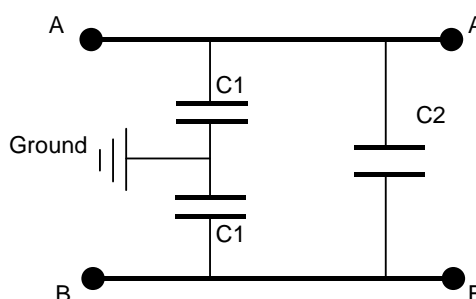
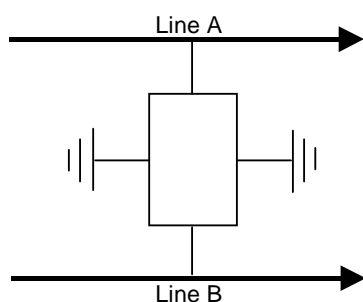



Technical Benefits

- Simultaneous line-to-line and line-to-ground filtering in one device.
- Replaces chokes, inductors, and capacitors with an SMT single chip solution.
- Reduces 2 or more components with one device.
- Matched capacitance line-to-ground on both lines.
- Low inductance due to cancellation effect.
- Differential and common mode attenuation.
- Effects of temperature and voltage variation eliminated.

Applications

- Balanced lines.
- Twisted pairs.
- EMI suppression on DC motors.
- Sensor/ transducer applications.
- Wireless communications.
- Audio.

Reliability Information

- Load Test

Samples taken during the development process and from production batches have been subjected to a standard load test. Load test information and results:

Time period analyzed: 1997 to 06 January 2005.

Number of capacitors tested: 10270

Product group analysed: All X2Y products sample tested.

Testing location: Syfer Reliability Test Department.

Endurance test conditions: Up to 1000 hours with 1.5x Rated Voltage applied at 125°C.

Results: 6 failures in 10,215,360 component test hours.



The load test results have then been used to calculate FIT (Failure In Time) rates by applying voltage and temperature acceleration factors.

For details regarding the FIT rate calculation method including acceleration factors then refer to Syfer application note reference AN0004.

X2Y FIT Rates

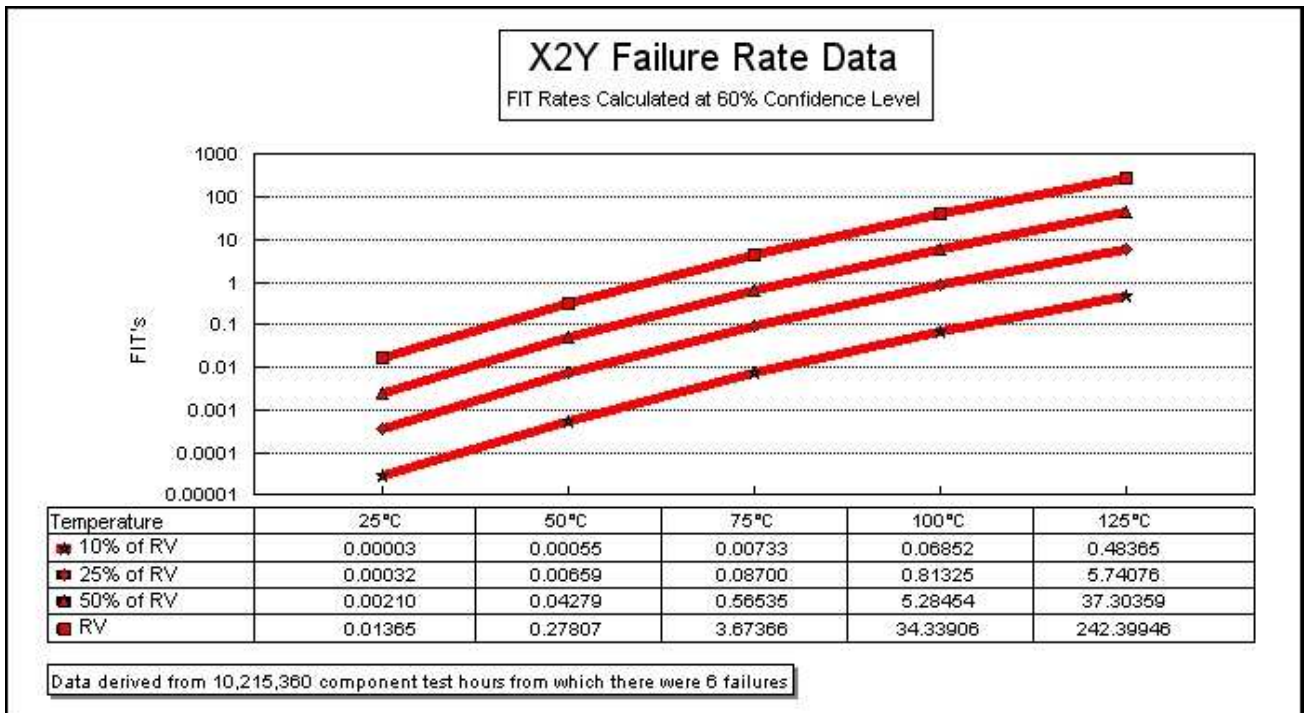

FIT Rate Reliability Conversion Factors

From	To	Operation
FITS	MTBF (Years)	$\frac{10^9}{(FITS \times 8760)}$
FITS	Failure Rate Per Hour	$\frac{FITS}{10^9}$
FITS	ppm (1 year)	$\frac{FITS \times 8760 \times 1,000,000}{10^9}$

FITS = Failures in 10⁹ Hours

MTBF = Mean Time Between Failures



- Humidity Tests

Samples taken during the development process and from production batches have been subjected to a standard humidity test. Humidity test information and results:

Time period analyzed: 1997 to 06 January 2005.
Number of capacitors tested: 719
Product group analysed: All X2Y products sample tested.
Testing location: Syfer Reliability Test Department.
Endurance test conditions: Up to 1000 hours with 85°C/85%RH with 1.5Vdc or 5Vdc applied.
Results: 0 failures in 552,600 component test hours.

Performance Information

- Capacitance vs. Time

Typical COG performance:

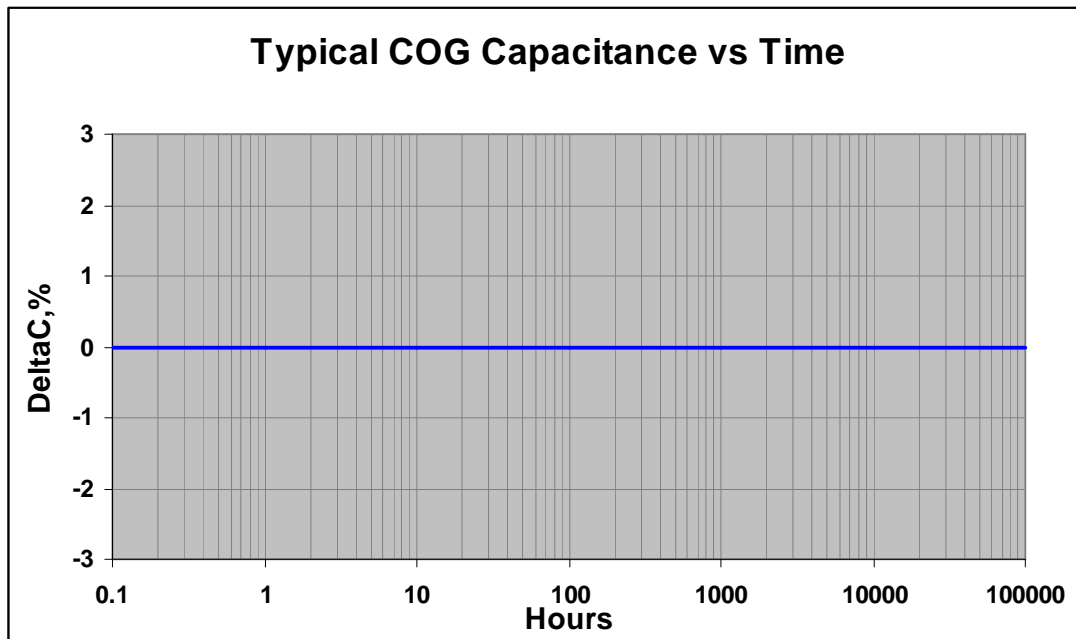



Typical X7R performance:

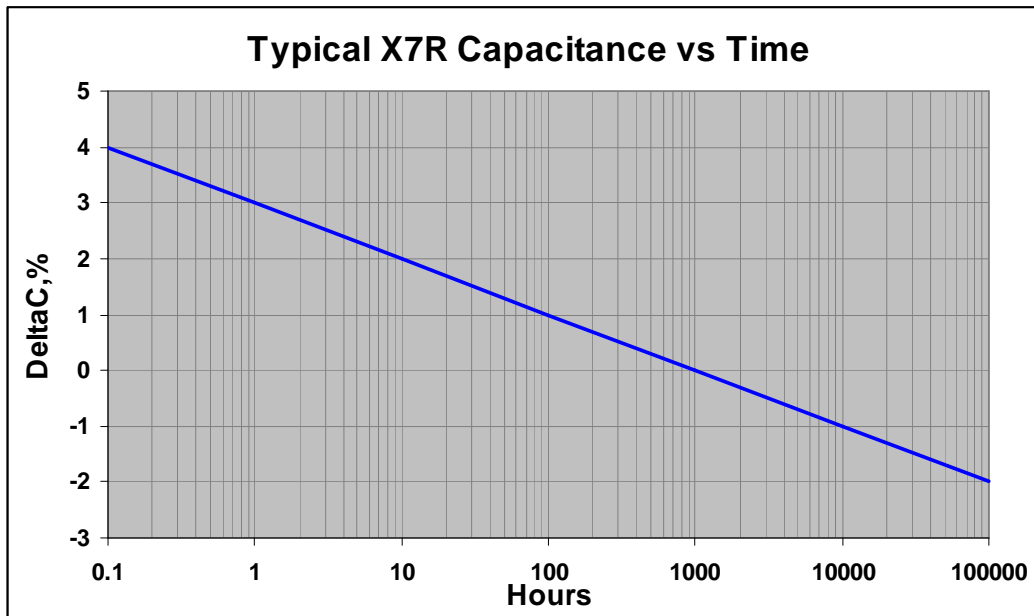

- IR vs. Temperature

Typical COG performance:

Greater than 100GOhms or 1000S over the operating temperature range.

Typical X7R performance:

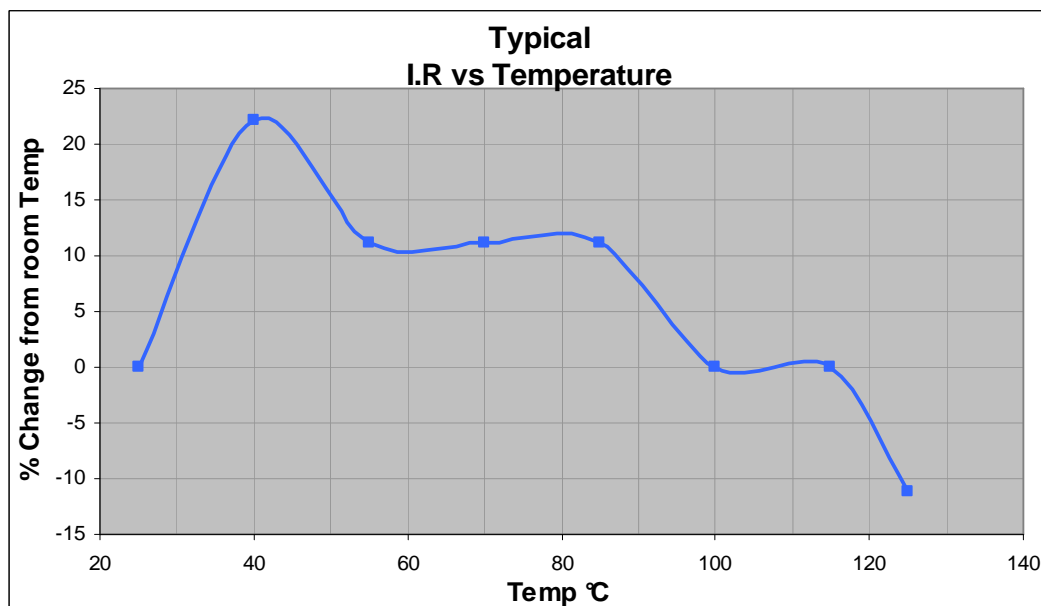



- DF vs. Temperature

Typical maximum COG performance:

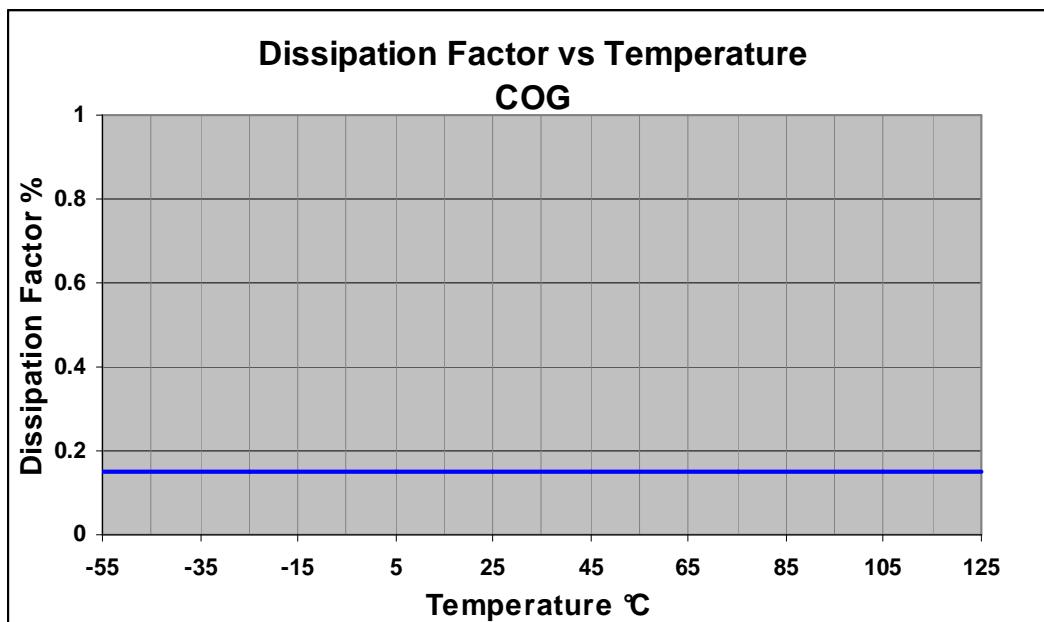

Typical X7R performance:

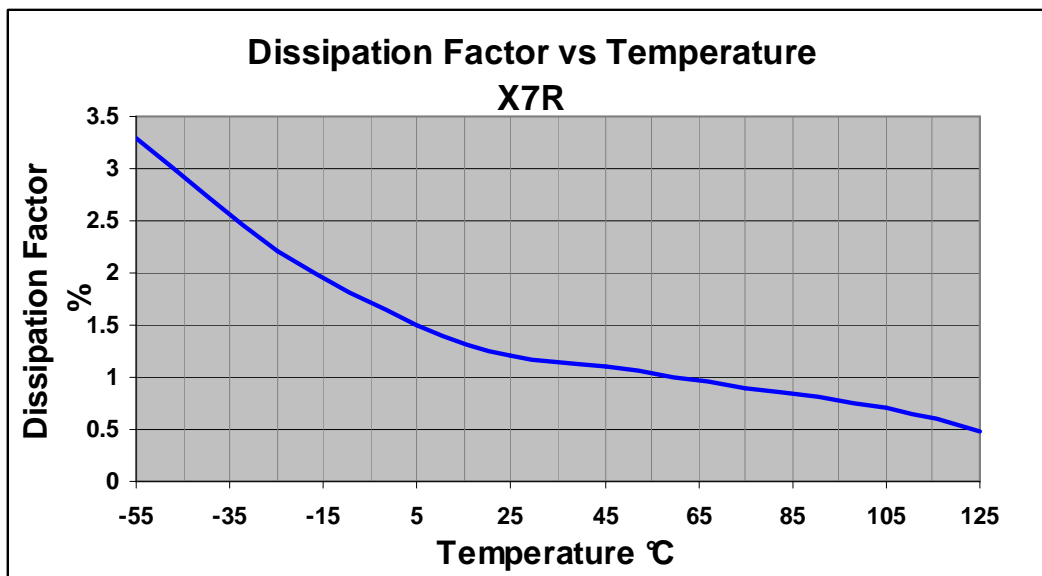



▪ Rated Voltage vs. Temperature

Typical COG performance:

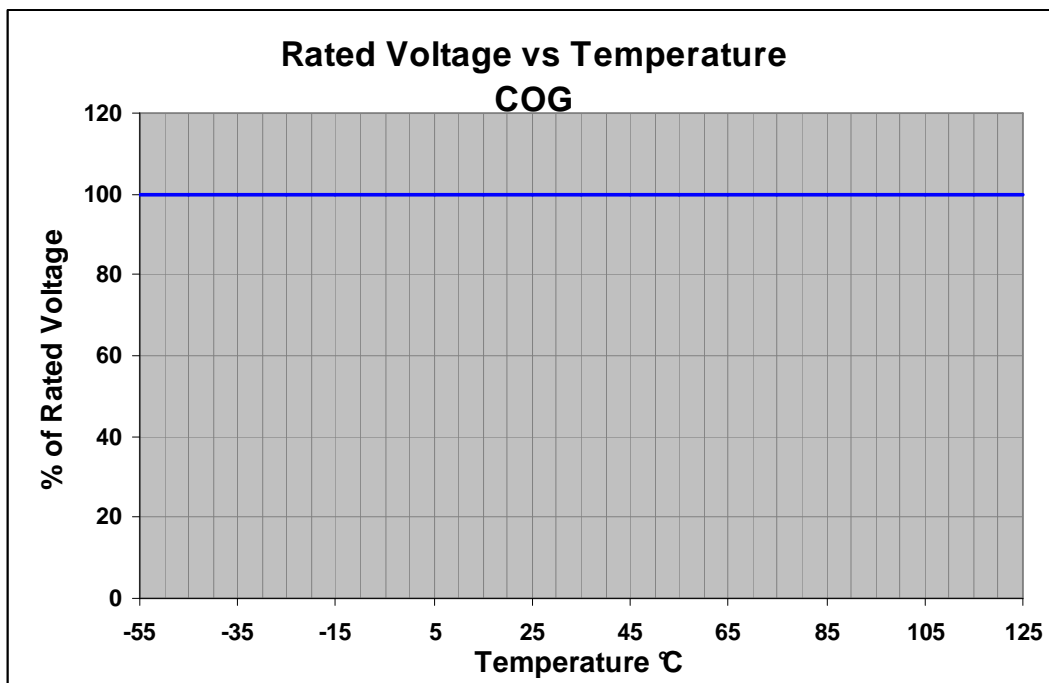

Typical X7R performance:

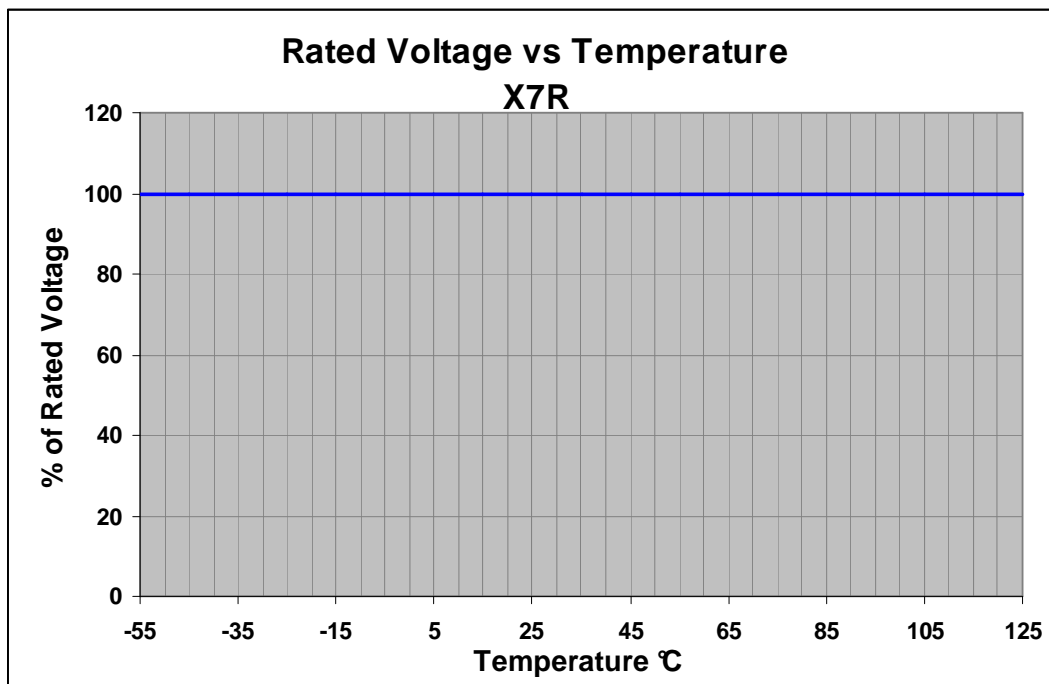



- Temperature Coefficient

Typical COG performance:

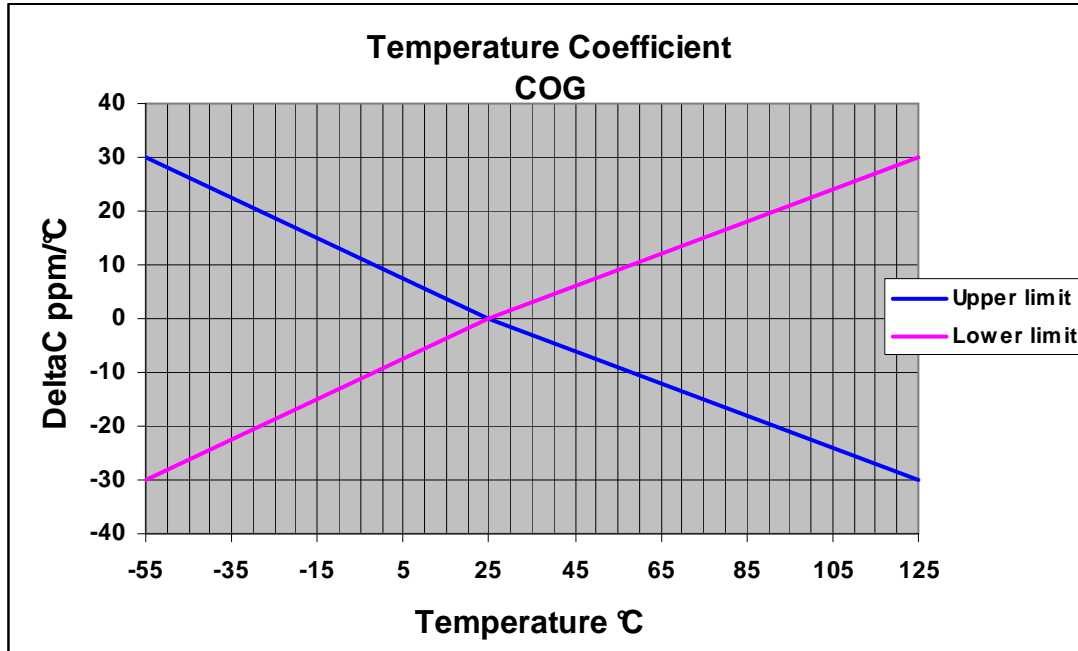

Typical X7R performance:

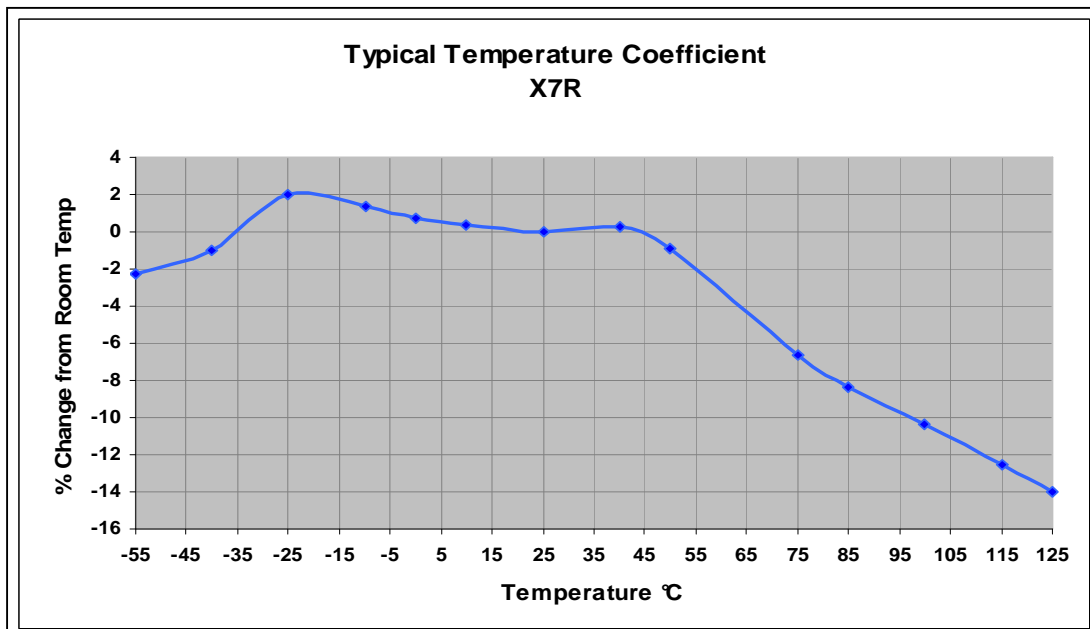



- Voltage Coefficient

Typical COG performance:

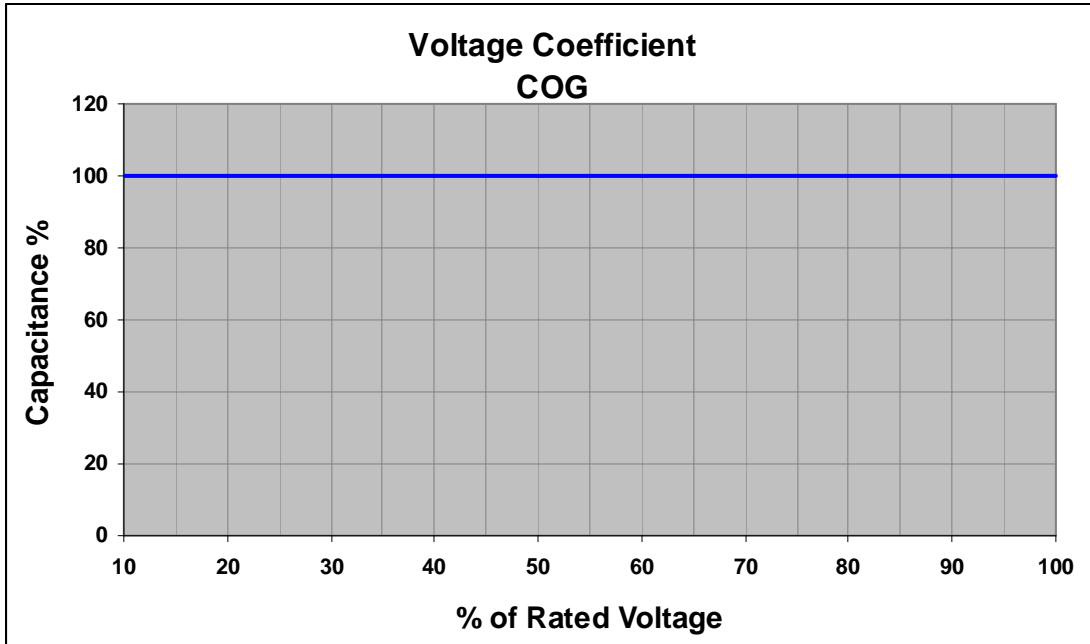

Typical X7R performance (50DCV Rated):

