



Syfer Technology Limited, Old Stoke Road,
Arminghall, Norwich, Norfolk, NR14 8SQ,
United Kingdom
Tel: +44 (0) 1603 723300.
Tel. (Sales): 01603 723310
Fax: +44 (0) 1603 723301
Email: sales@syfer.co.uk
Web: www.svfer.com

The Effect of Lead Free Soldering on Bend Test Performance

Methods and International Specifications

<u>Introduction</u>	2
<u>International Requirements/ Specifications</u>	2
<u>Capacitor Bend Tests Conducted on Syfer Product</u>	3
<u>Mechanical Crack Shape</u>	5
<u>Summary</u>	6
<u>The Effect of Pb Free Solders on Mechanical Cracking of MLCC's</u>	7
<u>Lead Free Bend Test Results</u>	8
<u>Lead Free Bend Test Conclusion</u>	9

Introduction

Due to its brittle nature, multilayer ceramic capacitors are more prone to excesses of mechanical stress than other components used in surface mounting. One of the most common causes of capacitor failures is directly attributable to the bending of the printed circuit board (PCB) after solder attachment. Excessive bending will create mechanical stress within the ceramic capacitor that, if sufficient, can result in mechanical cracks.

The introduction of lead free solders for attachment of chip capacitors to PCB's has raised a further area of concern in that lead free solders are less ductile than their traditional tin/lead equivalents. This raises the possibility that the lead free solders demanded by the EU RoHS directive could cause an increase in the incidences of chip failure due to mechanical cracking as stress is transferred to the chip rather than absorbed by the solder.

The purpose of this report is to provide details regarding:

- a. For background information, methods employed by Syfer to measure the mechanical performance of the termination material.
- b. For background information, the shape of cracks created by PCB bending - mechanical stress.
- c. Testing carried out by Syfer to determine the effects of lead free solders on the mean bend performance of ceramic chip capacitors.

Capacitor Bend Tests Conducted on Syfer Product

Currently there are 2 methods employed by Syfer to measure the mechanical performance of capacitor termination when mounted on a substrate:

1. External Test Laboratory

To maintain CECC product approval (certified by BSI "British Standards Institute") Syfer issues capacitor samples to an external test laboratory for a variety of tests to be conducted in accordance with CECC requirements. The external test laboratory is not part of Syfer and has full traceability to International Reference Standards. This is useful in allowing Syfer to cross reference results obtained from in house testing.

Syfer has maintained CECC product approval for >10 years.

2. Syfer Bend Tests

In addition to the external test laboratory Syfer also conducts bend tests. Samples of capacitors are mounted onto FR4 Test PCBs using 60/40 Sn/Pb solder and subjected to bend testing in accordance with CECC/ IEC requirements.

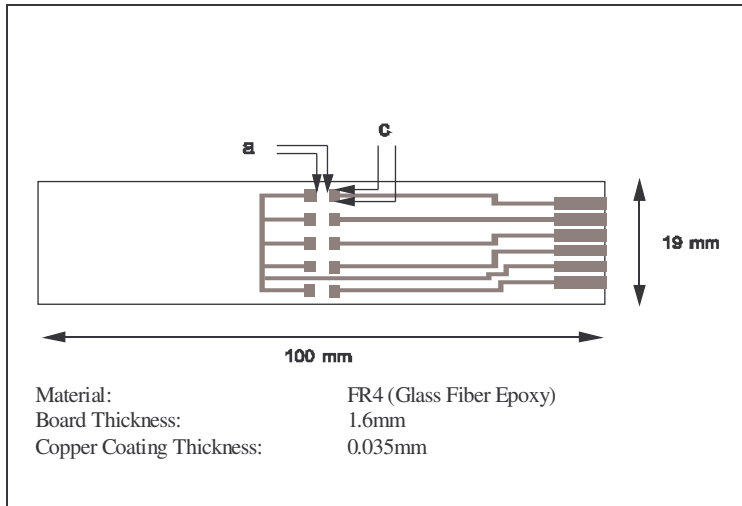

Example of FR4
Test PCB Used

Capacitor Placement Method



Hand pick and place used to
mount capacitors for bend tests.

Syfer's Bend Test Facility

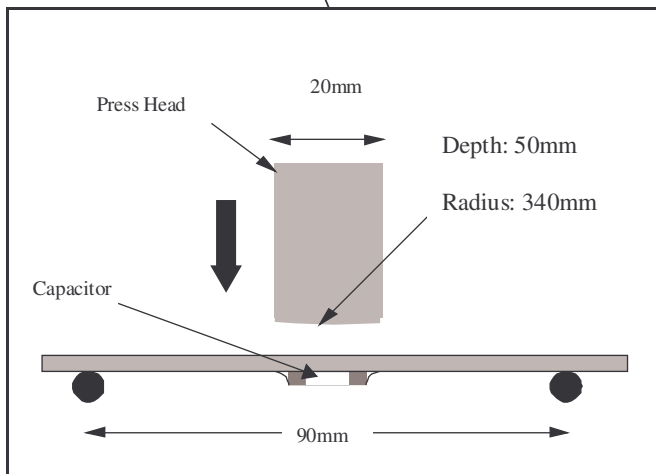

Fig 1. Bend Test Method

A total of 16 Test PCBs are used for each bend test. Each PCB is mounted with either 2, 3 or 5 capacitors depending upon capacitor size and 4 Test PCBs are used for each deflection depth.

In addition to Capacitance measurements, after deflection capacitors are carefully removed using a hot air pencil and then micro-sectioned to determine the presence of mechanical cracks. The reason for performing the micro-section is that extensive trials conducted by Syfer have demonstrated that measuring Capacitance does not provide a clear indication if the capacitors are cracked.

Typical results for Syfer X7R 0805, 1206, 1812 and 2220 capacitor ranges (soldered with traditional SnPb solder) :

PRODUCT	MEAN BEND (mm)
0805 X7R	3.6
1206 X7R	3.4
1812 X7R	3.2
2220 X7R	3.2

Mechanical Crack Shape

By conducting extensive bend testing capacitor manufacturers including Syfer have demonstrated that mechanical stress applied by bending the PCB results in a distinctive type of crack within the capacitor.

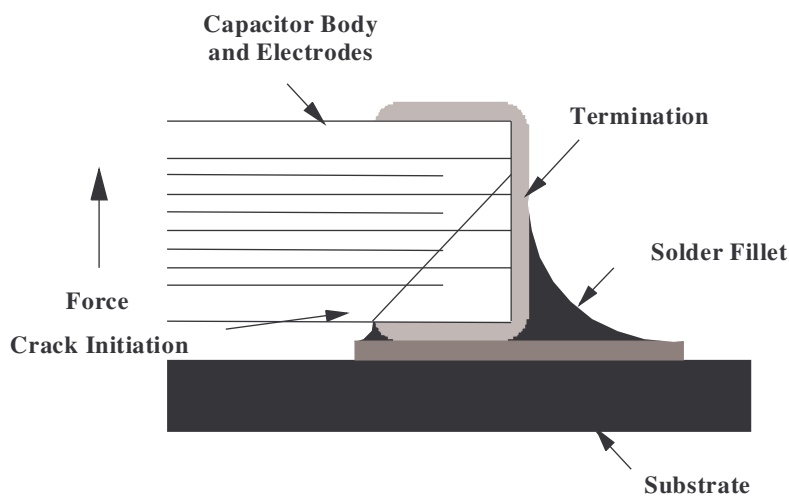
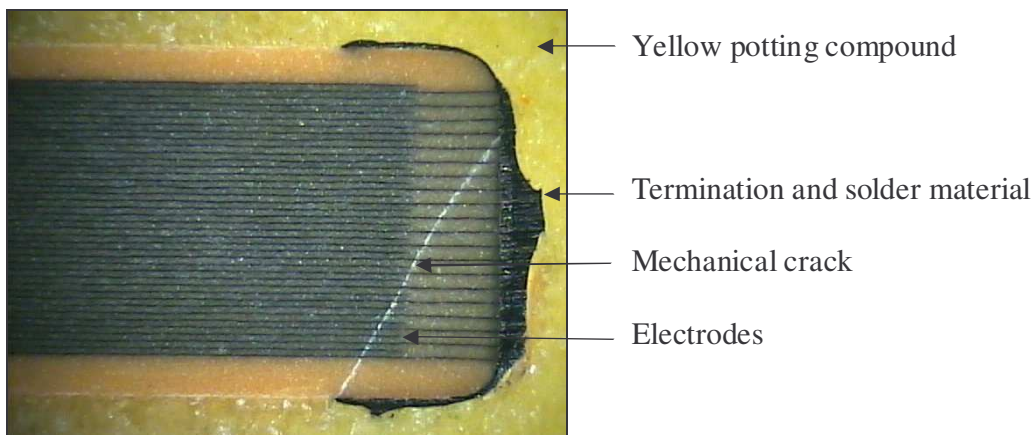

Fig 2. Mechanical Crack

During Syfer's initial investigation into mechanical cracking over 15000 capacitors were subjected to bend testing.

Example of capacitors issued by customers to Syfer for failure investigation:



Summary

- Syfer capacitors pass the International Specifications for bend testing. In addition to routine tests conducted at Syfer an external test laboratory conducts periodic CECC tests on Syfer product including bend testing.
- The crack created by mechanical stress during PCB bending is a distinctive type of crack.

For further information regarding:

- a). Potential causes for mechanical cracking refer to Syfer application note “mc-potential causes”.
- b). An alternative termination material that withstands higher levels of mechanical stress refer to Syfer application note “FlexiCapTM Termination”.

The Effect of Lead Free Solders on Mechanical Cracking of MLCC's

As mentioned above, one concern with lead free solders is that the reduced ductility in the solder could lead to increased incidences of mechanical cracking of the ceramic.

To ascertain if this concern was real, Syfer instigated a test program to compare the bend test results of a number of 1206 size X7R chip capacitors when soldered with conventional tin/lead (Sn/Pb) solders and with a common lead free solder alloy - 95.5/3.8/0.7 SnAgCu (SAC). Both conventional 'J' chip termination (plated tin over nickel over Silver/glass termination material) and Syfer 'Y' FlexiCap™ (plated tin over nickel over flexible Silver polymer termination material) were tested and ageing at ambient temperature was taken into account to evaluate if the subtle changes in solder particle size over time had any effect.

Testing Carried Out.

- Mount 80 capacitors of each of 5 types of conventionally terminated capacitors to boards using 60/40 SnPb solder and carry out bend testing as above.
- Mount 80 capacitors of each of 5 types of FlexiCap™ terminated capacitors to boards using 60/40 SnPb solder and carry out bend testing as above.
- Mount 80 capacitors of each of 5 types of conventionally terminated capacitors to boards using 95.5/3.8/0.7 SAC solder and carry out bend testing as above.
- Mount 80 capacitors of each of 5 types of FlexiCap™ terminated capacitors to boards using 95.5/3.8/0.7 SAC solder and carry out bend testing as above.
- Mount 80 capacitors of each of 5 types of conventionally terminated capacitors to boards using SAC solder, allow to age for 1000hrs at ambient temperature and carry out bend testing as above.
- Mount 80 capacitors of each of 5 types of FlexiCap™ terminated capacitors to boards using SAC solder, allow to age for 1000hrs at ambient temperature and carry out bend testing as above.

Total number of capacitors tested = 2400.

Where conventional SnPb solder was used, board finish was Hot Air Solder Levelled (HASL). Where Pb free solder (SAC) was used, board finish was gold (Au) flash over nickel (Ni) plate (NIG).

All boards were assembled using hot air reflow methods. Peak solder temperatures were 220°C for SnPb and 260°C for SAC solder. In both cases, parts were allowed to cool naturally to ambient temperature – forced cooling was not used as this can itself induce cracks in the ceramic giving false results.

Results

For each set of tests, the results, consisting of the number of fractures and capacitance failures at each bend distance, are entered into a database and the mean bend distance is calculated.

These mean bends can then be compared to evaluate the effect of the two different solders.

Chip Size	Termination	Mean Bend SnPb Solder (mm)	Mean Bend SnAgCu Solder (mm)	Difference in mean bend between conventional and Pb free solders
1206	'J' Termination	3.4	3.2	- 0.2mm
	'Y' FlexiCap™	6.7	6.5	- 0.2mm

After ageing for 1000hrs :-

Chip Size	Termination	Mean Bend SnAgCu Solder 0hrs @ 25°C (mm)	Mean Bend SnAgCu Solder 1000hrs @ 25°C (mm)
1206	'J' Termination	3.2	3.5
	'Y' FlexiCap™	6.5	6.7

As solder ages it will change its internal grain structure, which can change the effect it has on the ceramic during bending. The results above show that the mean bend angle does change with prolonged storage and that after 1000hrs at ambient the two types of solder tend towards the same result.



Conclusion

Soldering with lead free solders marginally reduces the mean bend performance of multilayer chip capacitors mounted on a circuit board.

This change is small, and provided the normal recommendations are observed is unlikely to cause any significant problem within a lead free process. However, where an existing process is 'on the edge' the change to lead free may be sufficient to cause processing problems.

Given time, the grain structure within the solder joint will age to a similar structure to that of lead containing solders and the mean bends for both solders will be very similar.

Although Syfer's FlexiCap™ showed a similar marginal decline in performance when soldered with lead free, in all tests it continued to significantly outperform the conventional termination and is therefore the preferred choice for lead free soldering.

Further information on FlexiCap™ is available on Syfer's web site www.syfer.com